

# D68000

## 16/32-bit Microprocessor ver 1.15

### OVERVIEW

D68000 soft core is binary-compatible with the industry standard 68000 32-bit microcontroller. D68000 has a 16-bit data bus and 24-bit address data bus. It is code compatible with the MC68008 and is upward code compatible with the MC68010 virtual extensions and the MC68020 32-bit implementation of the architecture. D68000 has improved instructions set allows execution of a program with higher performance than standard 68000 core.

D68000 is delivered with **fully automated test-bench** and **complete set of tests** allowing easy package validation at each stage of SoC design flow.

### KEY FEATURES

- Software compatible with industry standard 68000
- **MULS, MULU take 28 clock periods**
- **DIVS, DIVU take 28 clock periods**
- Optimized shifts and rotations
- Idle cycles removed to improve performance
- Shorter effective address calculation time
- Bus cycle timings **identical** to 68000
- 32 bit data and address registers
- 14 addressing modes:
  - *Direct:*
    - *Data register direct*
    - *Address register direct*
  - *Indirect:*
    - *Register indirect*

- *Postincrement register indirect*
- *Predecrement register indirect*
- *Register indirect with offset*
- *Indexed register indirect with offset*
- *PC relative:*
  - *Relative with offset*
  - *Relative with index and offset*
- *Absolute data:*
  - *Absolute short*
  - *Absolute long*
- *Immediate data:*
  - *Immediate*
  - *Quick immediate*
- *Implied*

- 5 data types supported:
  - *bits*
  - *BCD*
  - *bytes, words and long words*
- Arithmetic Logic Unit includes:
  - *8, 16, 32-bit arithmetic & logical operations*
  - *16x16 bit signed and unsigned multiplication*
  - *32/16 bit signed and unsigned division*
  - *Boolean operations*
- Interrupt controller:
  - *7 priority levels interrupt controller*
  - *Unlimited number of virtual interrupt sources*
  - *Vectored and auto-vectored modes*
- Memory interface includes:

All trademarks mentioned in this document are trademarks of their respective owners.

<http://www.DigitalCoreDesign.com>  
<http://www.dcd.pl>

- Up to 4 GB of address space
- 16-bit data bus
- Asynchronous bus control
- M6800 family synchronous interface
- 3- and 2- wire bus arbitration
- Supervisor and user modes
- Fully synthesizable, static synchronous design with no internal tri-states

## SYMBOL

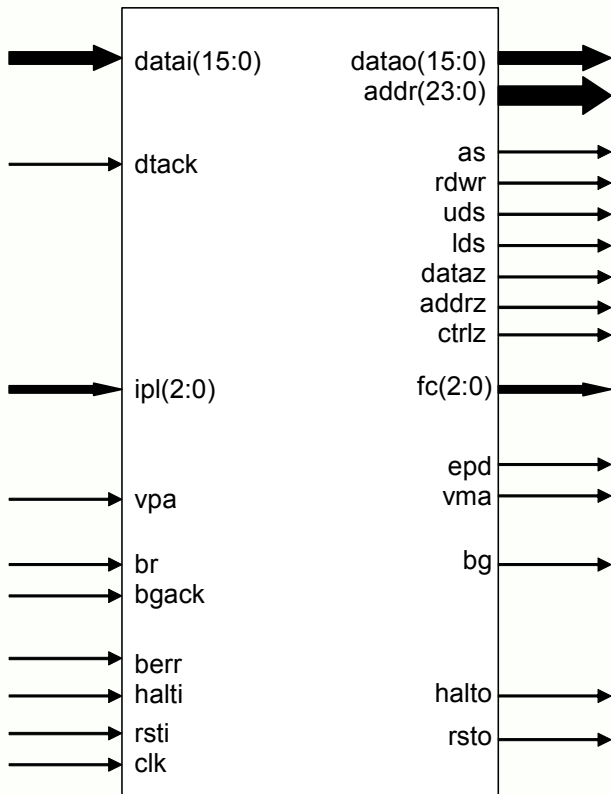

## PINS DESCRIPTION

PIN	TYPE	ACTIVE	DESCRIPTION
clk	input	High	Global clock
rsti	input	Low	Global reset input
halti	input	Low	Halt input
berr	input	Low	Bus error
vpa	input	Low	Valid peripheral address
ipl(2:0)	input	Low	Interrupt control
dtack	input	Low	Data transfer acknowledge
br	input	Low	Bus request
bgack	input	Low	Bus grant acknowledge
datai[15:0]	input	-	Data bus input
datao[15:0]	output	-	Data bus output
addr[23:0]	output	-	Address data bus
bg	output	Low	Bus grant
as	output	Low	Address strobe
rdwr	output	High/Low	Read write signal
uds	output	Low	Upper data byte strobe
lds	output	Low	Lower data byte strobe
addrz	output	High	Turns Address bus into 'Z' state
dataz	output	High	Turns Data bus into 'Z' state
ctrlz	output	High	Turns as, rdwr, uds, lds, vma, fc(2:0) signals into 'Z' state
fc(2:0)	output	High	Processor function code
epd	output	High	Enable peripheral device
vma	output	Low	Valid memory address
halto	output	Low	Halt output
rsto	output	Low	Reset output

## DELIVERABLES

- ◆ Source code:
  - ◇ VHDL Source Code or/and
  - ◇ VERILOG Source Code or/and
  - ◇ Encrypted, or plain text EDIF netlist
- ◆ VHDL & VERILOG test bench environment
  - ◇ Active-HDL automatic simulation macros
  - ◇ ModelSim automatic simulation macros
  - ◇ Tests with reference responses
- ◆ Technical documentation
  - ◇ Installation notes
  - ◇ HDL core specification
  - ◇ Datasheet
- ◆ Synthesis scripts

All trademarks mentioned in this document are trademarks of their respective owners.

<http://www.DigitalCoreDesign.com>  
<http://www.dcd.pl>

- ◆ Example application
- ◆ Technical support
  - ◇ IP Core implementation support
  - ◇ 3 months maintenance
    - Delivery the IP Core updates, minor and major versions changes
    - Delivery the documentation updates
    - Phone & email support

## LICENSING

Comprehensible and clearly defined licensing methods without royalty per chip fees make using of IP Core easy and simply.

Single Site license option is dedicated for small and middle sized companies making its business in one place.

Multi Sites license option is dedicated for corporate customers making its business in several places. Licensed product can be used in selected branches of corporate.

In all cases number of IP Core instantiations within a project, and number of manufactured chips are unlimited. The license is royalty per chip free. There is no time of use restrictions.

There are two formats of delivered IP Core

- VHDL, Verilog RTL synthesizable source code called HDL Source
- FPGA EDIF/NGO/NGD/QXP/VQM called Netlist

## BLOCK DIAGRAM

**ALU** – Arithmetic Logic Unit performs the arithmetic and logic operations during execution of an instruction. It contains accumulator and related logic such as arithmetic unit, logic unit, multiplier and divider. BCD operation are executed in this unit and condition code flags (N-negative, Z-zero, C-carry V-overflow) for most instructions.

**Shifter** – Performs shifting operations for the appropriate instructions, mainly for rotation, shift and bit operations.

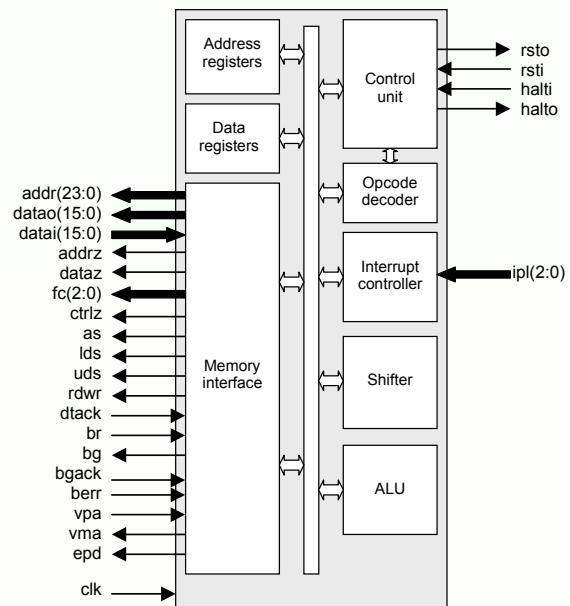

**Control Unit** – Performs the core synchronization and data flow control. This module manages execution of all instructions. Contains SR (status register is consisted of two portions supervisor byte and user byte) and its related logic.

**Opcode Decoder** – Performs an instruction opcode decoding and the control functions for all other blocks.

**Memory Interface** – Contains memory access related registers. It performs the memory addressing instructions code fetching and data transfers. It is responsible for all external bus cycle actions such as: read & write, repeated read & write, halt and resume of bus cycles, bus arbitration provided by 3- and 2- wire system, correct bus and address errors handling, wait states cycle insertion and M6800 synchronous cycle generation.

**Interrupt Controller** – Interrupt Control module is responsible for the interrupt manage system for the external & internal interrupts and exceptions processing. It manages auto-vectored interrupt cycles, priority resolving and correct vector numbers creation.

**Address registers** – Contains 32-bit A0 to A6 address registers, two stack pointers USP (user SP) and SSP (Supervisor SP), 32-bit Program counter and related logic to perform word and

long address operations. An effective address operation are executed in this unit.

**Data registers** – Contains 32-bit data registers D0 to D7 and related logic to perform byte, word and long data operations.

## PERFORMANCE

The following tables give a survey about the Core area and performance in the ASICs Devices after Place & Route (all CPU features and peripherals have been included):

Device	Gates
0.25u typical	24 000

*Core performance in ASIC devices*

## CONTACTS

For any modification or special request please contact to Digital Core Design or local distributors.

### Headquarters:

Wroclawska 94

41-902 Bytom, POLAND

e-mail: [info@dcd.pl](mailto:info@dcd.pl)

tel. : +48 32 282 82 66

fax : +48 32 282 74 37

### Distributors:

Please check <http://www.dcd.pl/apartn.php>