

DCORDIC

CORDIC processor

ver 1.16

OVERVIEW

The DCORDIC uses the **CORDIC** algorithm to compute **trigonometric**, reverse trigonometric, **hyperbolic** and reverse hyperbolic functions.

It supports sine, cosine, arcus tangent functions for hyperbolic and trigonometric systems. Logarithm, square root and exponent functions can also be computed. It supports fixed point 24-bit numbers.

OPERATING MODES

- Trigonometric system
- Hyperbolic system
- Rotation mode
- Vectoring mode

APPLICATIONS

- DSP algorithms
- Digital filtering
- Math coprocessors

KEY FEATURES

- 24-bit precision (IEEE-754 single precision real mantissa format)
- 4-ulp accuracy (34-bit internal registers)
- Fully configurable
- Performs the following functions:
 - ◇ $\sin(\theta)$, $\cos(\theta)$
 - ◇ $\sinh(\theta)$, $\cosh(\theta)$
 - ◇ $\arctan(x)$
 - ◇ $\operatorname{arctanh}(x)$

All trademarks mentioned in this document are trademarks of their respective owners.

◇ $\ln(x)$, e^x , \sqrt{x}

DELIVERABLES

- ◆ Source code:
 - ◇ VHDL Source Code or/and
 - ◇ VERILOG Source Code or/and
 - ◇ Encrypted, or plain text EDIF netlist
- ◆ VHDL & VERILOG test bench environment
 - ◇ Active-HDL automatic simulation macros
 - ◇ ModelSim automatic simulation macros
 - ◇ Tests with reference responses
- ◆ Technical documentation
 - ◇ Installation notes
 - ◇ HDL core specification
 - ◇ Datasheet
- ◆ Synthesis scripts
- ◆ Example application
- ◆ Technical support
 - ◇ IP Core implementation support
 - ◇ 3 months maintenance
 - Delivery the IP Core updates, minor and major versions changes
 - Delivery the documentation updates
 - Phone & email support

<http://www.DigitalCoreDesign.com>
<http://www.dcd.pl>

LICENSING

Comprehensible and clearly defined licensing methods without royalty per chip fees make using of IP Core easy and simply.

Single Site license option is dedicated for small and middle sized companies making its business in one place.

Multi Sites license option is dedicated for corporate customers making its business in several places. Licensed product can be used in selected branches of corporate.

In all cases number of IP Core instantiations within a project, and number of manufactured chips are unlimited. The license is royalty per chip free. There is no time of use restrictions.

There are two formats of delivered IP Core

- VHDL, Verilog RTL synthesizable source code called HDL Source
- FPGA EDIF/NGO/NGD/QXP/VQM called Netlist

SYMBOL

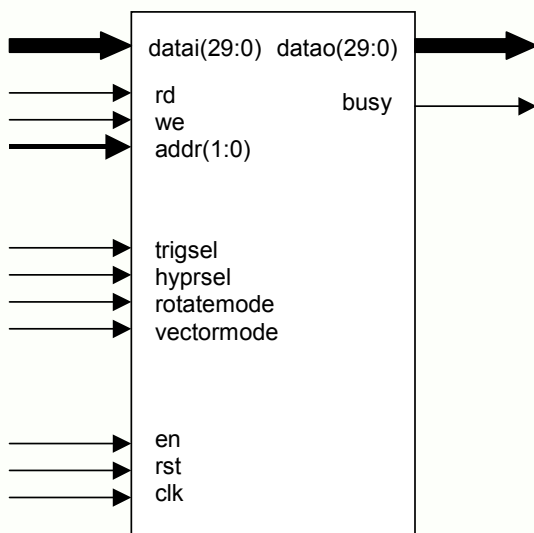

PINS DESCRIPTION

PIN	TYPE	DESCRIPTION
clk	Input	Global clock
rst	Input	Global reset

All trademarks mentioned in this document are trademarks of their respective owners.

PIN	TYPE	DESCRIPTION
en	Input	Enable computing
dataai[29:0]	Input	Data bus (input)
we	Input	Write data into register
rd	Input	Read data from register
cs	Input	Chip select
addr[1:0]	Input	Select register to read/write
rotatemode	Input	Rotate mode select
vectormode	Input	Vectoring mode select
hyprsel	Input	Hyperbolic system select
trigsel	Input	Trigonometric system select
dataao[29:0]	Output	Data bus (output)
busy	Output	Busy indicator

BLOCK DIAGRAM

ROM – stores constant coefficients used for hyperbolic and trigonometric operations.

Registers – contains all data registers hold temporary operation results as well as final results. Input arguments are written to this register also.

Control Unit – maintains control operation on *Registers* module, *Shifters* module and *ROM* unit, while busy is active.

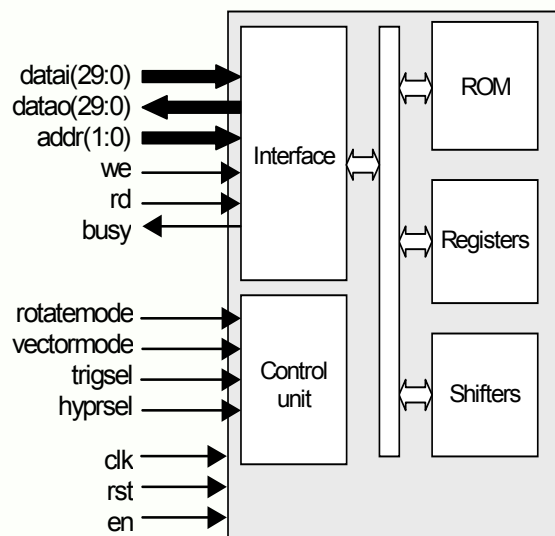

Shifters – performs shifting operations in

<http://www.DigitalCoreDesign.com>
<http://www.dcd.pl>

successful iterations. Number of shifts vary and depend on internal iteration cycle and computed functions.

Interface – performs communication between internal CORDIC modules and external devices. Signalizes when output registers contain a valid result.

CONTACTS

For any modification or special request please contact to Digital Core Design or local distributors.

Headquarters:

Wroclawska 94

41-902 Bytom, POLAND

e-mail: info@dcd.pl

tel. : +48 32 282 82 66

fax : +48 32 282 74 37

Distributors:

Please check <http://www.dcd.pl/apartn.php>