

DT8051

Tinny Area 8051-compatible Microcontroller ver 4.70

OVERVIEW

DT8051 is area optimized tiny soft core of a single-chip 8-bit embedded microcontroller based on World's fastest and most popular DP8051 core available for over 8 years.

DT8051 soft core is 100% binary-compatible with the industry standard 8051 8-bit microcontroller. DT8051 has **very low gate count** architecture giving **7 150 ASIC gates for complete system** including DoCD on-chip debugger. Dhrystone 2.1 benchmark program runs exactly **8.1 times faster than the original 80C51 at the same frequency**. DT8051 includes **2-wire** DoCD on-chip debugger (TTAG™), eight external interrupt sources, advanced Power Management Unit, Timers 0&1, I/O bit addressable Ports, full duplex UART and interface for external SFR.

DT8051 Core has built in support for the **2-wire** TTAG™ interface - DCD Hardware Debug System called DoCD™. This version of debugger is dedicated for applications where number of external pins is limited. DoCD™ is a **real-time hardware debugger** which provides **non-intrusive debugging** capability of a whole System on Chip (SoC). It can halt, run, step into or skip an instruction, set breakpoints, watchpoints, read/write any contents of microcontroller including all registers, internal, external, program memories, all SFRs including user defined peripherals.

The DT8051 is delivered with **fully automated testbench** and **complete set of tests** allowing easy package validation at each stage of SoC design flow.

KEY FEATURES

- Software compatible with industry standard 8051
- Very low gate count, area optimized architecture – **7 150 ASIC gates for complete system with DoCD on-chip debugger**
- 8.1 times faster than standard 8051
- **7.63 VAX MIPS at 100 MHz**
- Up to 256 bytes of internal (on-chip) Data Memory
- Up to 64k bytes of internal (on-chip) Program Memory
- Up to 64k bytes of external (off-chip) Program Memory
- Up to 64k bytes of external (off-chip) Data Memory
- De-multiplexed Address/Data Bus to allow easy connection to memory
- Power Management Unit
 - Power management mode
 - Switchback feature
 - Stop mode
- Interrupt Controller
 - 2 priority levels
 - 8 external interrupt sources
 - 3 interrupt sources from peripherals
- 8-bit I/O Port
 - Bit addressable data direction for each line
 - Read/write of single line and 8-bit group
- Two 16-bit timer/counters

- *Timers clocked by internal source*
- *Auto reload 8-bit timers*
- *Externally gated event counters*
- Full-duplex serial port
 - *8-bit asynchronous mode, variable baud rate*
 - *9-bit asynchronous mode, variable baud rate*
- Interface for additional Special Function Registers
- **2-wire DoCD™** debug unit
 - *Processor execution control*
 - *Run, Halt*
 - *Step into instruction*
 - *Skip instruction*
 - *Read-write all processor contents*
 - *Program Counter (PC)*
 - *Program Memory*
 - *Internal (direct) Data Memory*
 - *Special Function Registers (SFRs)*
 - *External Data Memory*
 - *Code execution breakpoints*
 - *two real-time PC breakpoints*
 - *unlimited number of real-time OPCODE breakpoints*
 - *Three independent Memory watchpoints*
 - *SFR, DATA, XDATA*
 - **2-wire** TTAG communication interface
- Fully synthesizable, static synchronous design with positive edge clocking and no internal tri-states
- Scan test ready

APPLICATIONS

- ◆ Low power battery operated devices
- ◆ Mixed signal systems
- ◆ Area optimized FPGA/ASIC design
- ◆ FSM replacements

BENEFITS

- ◆ The lowest gate count 8051 compatible architecture
- ◆ Very low power consumption
- ◆ Significant performance improvement with respect to the 80C51 device working at the same clock frequency (**8.1 in terms of Dhrystone MIPS**)
- ◆ On demand customization

DELIVERABLES

- ◆ Source code:
 - ◇ VHDL Source Code or/and
 - ◇ VERILOG Source Code or/and
 - ◇ FPGA Netlist
- ◆ VHDL & VERILOG test bench environment
 - ◇ Active-HDL automatic simulation macros
 - ◇ ModelSim automatic simulation macros
 - ◇ NCSim automatic simulation macros
 - ◇ Tests with reference responses
- ◆ Technical documentation
 - ◇ Installation notes
 - ◇ HDL core specification
 - ◇ Datasheet
- ◆ Synthesis scripts
- ◆ Example application
- ◆ Technical support
 - ◇ IP Core implementation support
 - ◇ 3 months maintenance
 - Delivery the IP Core updates, minor and major versions changes
 - Delivery the documentation updates
 - Phone & email support

SYMBOL

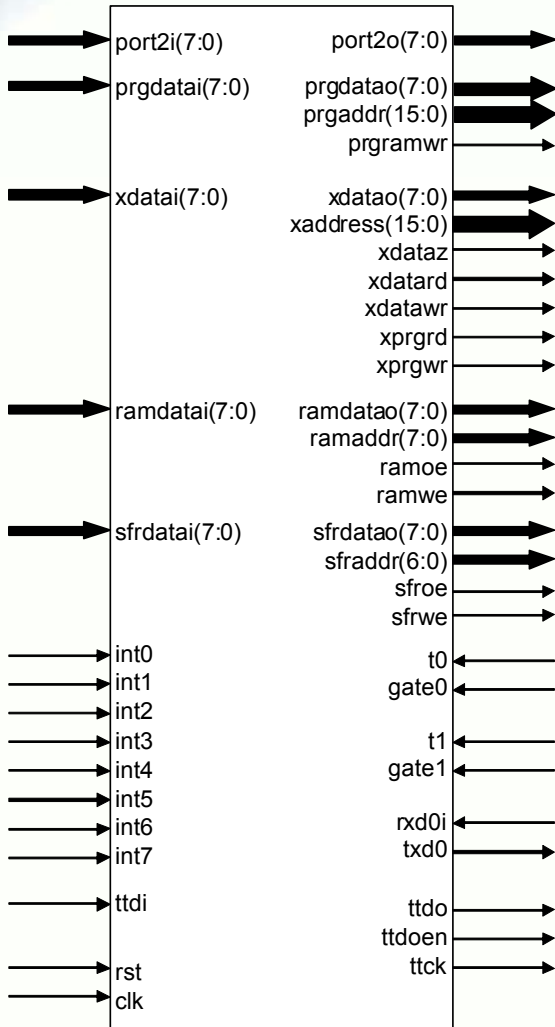

BLOCK DIAGRAM

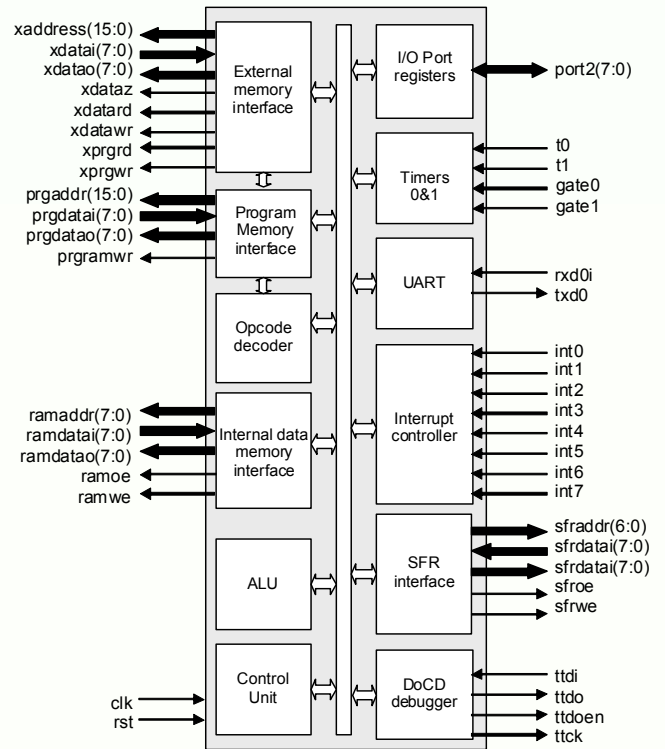

PINS DESCRIPTION

PIN	TYPE	DESCRIPTION
clk	input	Global clock
rst	input	Global reset
port2i[7:0]	input	Port 2 input
prgdatai[7:0]	input	Data bus from internal program memory
xdatai[7:0]	input	Data bus from external data/code memory
ramdatai[7:0]	input	Data bus from internal data memory
sfrdatai[7:0]	input	Data bus from user SFR's
int0	input	External interrupt 0
int1	input	External interrupt 1
int2	input	External interrupt 2
int3	input	External interrupt 3
int4	input	External interrupt 4
int5	input	External interrupt 5
int6	input	External interrupt 6
int7	input	External interrupt 7
t0	input	Timer 0 input
t1	input	Timer 1 input
gate0	input	Timer 0 gate input
gate1	input	Timer 1 gate input

PIN	TYPE	DESCRIPTION
rxdi	input	Serial receiver input
ttdi	input	DoCD data input
port2o[7:0]	output	Port 2 output
prgaddr[15:0]	output	Internal program memory address bus
prgdatao[7:0]	output	Data bus for Internal program memory
prgramwr	output	Internal program memory write
xaddress[15:0]	output	External data/code memory address bus
xdatao[7:0]	output	Data bus for external data/code memory
xdataz	output	External XDATA bus 'Z' state
xdatawr	output	External data memory write
xdatard	output	External data memory read
xprgrd	output	External program memory read
xprgwr	output	External program memory write
ramaddr[7:0]	output	RAM address bus
ramdatao[7:0]	output	Data bus for internal data memory
ramwe	output	Internal data memory write enable
ramoe	output	Internal data memory output enable
sfraddr[6:0]	output	SFR's address bus
sfrdatao[7:0]	output	Data bus for user SFR's
sfrwe	output	User SFR's write enable
sfroe	output	User SFR's output enable
txd	output	Serial transmitter output
ttck	output	DoCD clock output
ttdoen	output	DoCD data output enable
ttdo	output	DoCD data output

UNITS SUMMARY

ALU - Arithmetic Logic Unit performs the arithmetic and logic operations during execution of an instruction. It contains accumulator (ACC), Program Status Word (PSW), (B) registers and related logic like arithmetic unit, logic unit, multiplier and divider.

Control Unit - Performs the core synchronization and data flow control. This module manages execution of all instructions.

Program Memory Interface - Contains Program Counter (PC) and related logic. It performs the instructions code fetching. Whole program memory (FLASH or SRAM type) can be written by DoCD™ debugger, or application can modify some part of its code – for example storing some data which shouldn't volatile.

External Memory Interface - Contains memory access related registers like Data Page High
All trademarks mentioned in this document are trademarks of their respective owners.

(DPH) and Data Page Low (DPL) registers. It performs the memory addressing and data transfers.

Internal Data Memory Interface - Internal Data Memory interface controls access into the internal 256 bytes memory. It contains 8-bit Stack Pointer (SP) register and related logic.

SFR's Interface - Special Function Register interface manages communication between CPU and user specified special registers.

Opcode Decoder - Performs an instruction opcode decoding and the control functions for all other blocks.

Interrupt Controller - Interrupt Control module is responsible for the interrupt manage system for the external and internal interrupt sources. It contains interrupt related registers such as Interrupt Enable (IE), Interrupt Priority (IP), Extended Interrupt Enable (EIE), Extended Interrupt priority (EIP) and (TCON) registers.

Timers - System timers' module. Contains two 16 bits configurable timers: Timer 0 (TH0, TL0), Timer 1 (TH1, TL1) and Timers Mode (TMOD) registers.

UART - Universal Asynchronous Receiver & Transmitter module is full duplex, meaning it can transmit and receive concurrently. Includes Serial Configuration register (SCON), serial receiver and transmitter buffer (SBUF) registers. Its receiver is double-buffered, meaning it can commence reception of a second byte before a previously received byte has been read from the receive register. Writing to SBUF0 loads the transmit register, and reading SBUF0 reads a physically separate receive register. It works in 2 asynchronous modes with variable baudrate covering all standard transmission speeds.

Ports - Block contains 8051's general purpose I/O ports. Each of port's pin can be read/write as a single bit or as an 8-bit bus.

DoCD™ Debug Unit – it is a **2-wire low gate count** real-time hardware debugger providing debugging capability of a whole SoC system. In contrast to other on-chip debuggers, DoCD™ provides **non-intrusive** debugging of running application. It can halt, run, step into or skip an

instruction, read/write any contents of microcontroller including all registers, internal, external, program memories, all SFRs including user defined peripherals. Hardware breakpoints controls execution of program memory code; hardware watchpoints can be set and controls internal and external data memories, as well as SFRs. Hardware watchpoints are executed if any write/read occurred at particular address with certain data pattern or without pattern. Two additional pins CODERUN, DEBUGACS indicate the state of the debugger and CPU. CODERUN is active when CPU is executing an instruction. DEBUGACS pin is active when any access is performed by DoCD™ debugger. The DoCD™ system includes **TTAG interface** and complete set of tools to communicate and work with core in real time debugging. It is built as scalable unit and some features can be turned off to save silicon and reduce power consumption. A special care on power consumption has been taken, and when debugger is not used, it is automatically switched in power save mode. Finally whole debugger is turned off when debug option is no longer used.

PERFORMANCE

The following tables give a survey about the DT8051 and DoCD on-chip debugger area and performance in the most popular ASIC technologies (all features are included). **Results given for working system with connected SFR IDATA, CODE and XDATA memories.**

Technology / optimization	Speed grade	Area [gates]	F _{max}
0.25u area	typical	6 000	100 MHz
0.18u area	typical	5 720	130 MHz

DT8051 without DoCD debugger

Technology / optimization	Speed grade	Area [gates]	F _{max}
0.25u area	typical	7 530	100 MHz
0.18u area	typical	7 150	130 MHz

DT8051 with compact version¹ of DoCD debugger

Technology / optimization	Speed grade	Area [gates]	F _{max}
0.25u area	typical	8 150	100 MHz
0.18u area	typical	7 720	130 MHz

DT8051 with full version² of DoCD debugger

1- compact DoCD version includes processor execution control (*run, halt, reset, step*); read-write all processor content (*PC, SFRs*); read-write all processor memories (*IDATA, XDATA, CODE memory*); FLASH code memory programming; one hardware code execution breakpoint; unlimited number of OPCODE execution breakpoints

2- full DoCD version includes processor execution control (*run, halt, reset, step*); read-write all processor content (*PC, SFRs*); read-write all processor memories (*IDATA, XDATA, CODE memory*); FLASH CODE memory programming; two hardware code execution breakpoints; six configurable hardware watch-points (*IDATA, XDATA, SFRs*); unlimited number of OPCODE execution breakpoints

Dhrystone Benchmark Version 2.1 was used to measure Core performance. The following table gives a survey about the DT8051 performance in terms of Dhrystone/sec and VAX MIPS rating per 1 MHz (DMIPS/MHz).

Device	Dhry/sec [12 MHz]	DMIPS/MHz	80C51 ratio
80C51	197	0,0094	1,00
DT8051	1597	0,0763	8,11

DT8051 performance in terms of DMIPS/MHz

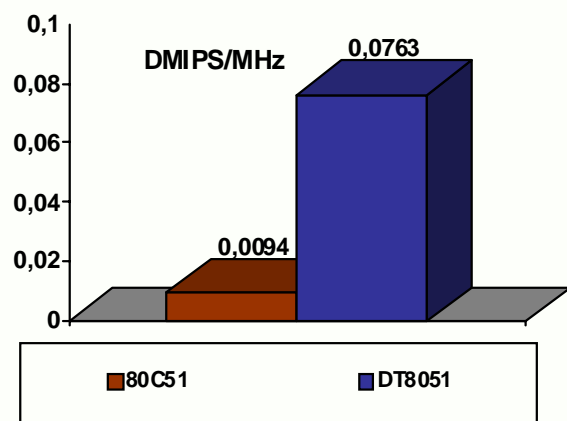

CONTACTS

For any modification or special request please contact to Digital Core Design or local distributors.

Headquarters:

Wroclawska 94

41-902 Bytom, POLAND

e-mail: info@dcd.pl

tel. : +48 32 282 82 66

fax : +48 32 282 74 37