

# DRPIC166X

## High Performance

### 8-bit RISC Microcontroller

#### ver 2.17

#### OVERVIEW

The DRPIC166X is a low-cost, high performance, 8-bit, fully static soft IP Core, dedicated for operation with **fast** (typically on-chip) dual ported **memory**. The core has been designed with a special concern about **low power consumption**.

DRPIC166X soft core is software-compatible with the industry standard PIC16C6X. It implements an **enhanced Harvard architecture** (i.e. separate instruction and data memories) with independent address and data buses. The 14 bit program memory and 8-bit dual port data memory allow instruction fetch and data operations to occur simultaneously. The advantage of this architecture is that instruction fetch and memory transfers can be overlapped by multi stage pipeline, so that the next instruction can be fetched from program memory while the current instruction is executed with data from the data memory. The DRPIC166X architecture is **4 times faster** compared to standard architecture. So most instructions are executed within **1 system clock period**, except the instructions which directly operates on program counter PC (GOTO, CALL, RETURN), this situation require the pipeline to be cleared and subsequently refilled. This operation takes additional one clock cycle.

The DRPIC166X Microcontroller fits perfectly in applications ranging from high-speed automotive and appliance motor control to low-power remote transmitters/receivers, pointing devices and telecom processors. Built-in power save mode make this IP perfect for applications where power consumption is critical.

DRPIC166X is delivered with **fully automated testbench** and **complete set of tests** allowing easy package validation at each stage of SoC design flow

The DRPIC1655X Microcontroller has built in **hardware on chip debugger – DoCD™**. This real time fully non-intrusive tool allows easy software debugging and validation on each step of the SoC System development

#### CPU FEATURES

- Software compatible with industry standard PIC16C6X
- **Hardware on Chip debugger – DoCD™**
- **Pipelined Harvard architecture 4 times faster compared to original implementation**
- 35 – 14 bit wide instructions
- **Up to 32K bytes of Data Memory**
- **Up to 64K bytes of Program Memory**
- Configurable hardware stack
- Power saving SLEEP mode
- Fully synthesizable, static synchronous design with no internal tri-states
- Technology independent HDL Source Code
- **1.4 GHz virtual** clock frequency in a 0.18μ technological process

## PERIPHERALS

- Four 8 bit I/O ports
  - Four 8-bit corresponding TRIS registers
  - Interrupt feature on PORTB(7:4) change
- Timer 0
  - 8-bit timer/counter
  - Readable and Writable
  - 8-bit software programmable prescaler
  - Internal or external clock select
  - Interrupt generation on timer overflow
  - Edge select for external clock
- Timer 1
  - 16-bit timer/counter
  - 3-bit prescaler
  - Internal or external clock select
  - Interrupt generation on timer overflow
- Timer 2
  - 8-bit timer with prescaler
- CCP – Compare-Capture-PWM
  - 16 Bit Compare/Capture operations
  - 10-bit resolution PWM output
- USART
  - Asynchronous – full duplex
  - Synchronous – half duplex Master/Slave
- Watchdog Timer
  - Configurable Time out period
  - 7-bit software programmable prescaler
  - Dedicated independent Watchdog Clock input
- Interrupt Controller
  - Seven individually maskable Interrupt sources
    - Two external interrupts – INT Port B[7:4] change
    - Five internal interrupts – TIMERS 0, 1, 2, USART
- DoCD™ debug unit
  - Processor execution control
    - Run
    - Halt
    - Step into instruction

- Skip instruction
- Read-write all processor contents
  - Program Counter (PC)
  - Program Memory
  - Data Memory
  - Special Function Registers (SFRs)
  - Hardware Stack and Stack Pointer
- Hardware execution breakpoints
  - Program Memory
  - Data Memory
  - Special Function Registers (SFRs)
- Three wire communication interface

## OPTIONAL PERIPHERALS

There are also available an optional peripherals, not included in presented DRPIC166X Microcontroller Core. The optional peripherals, can be implemented in microcontroller core upon customer request.

- SPI – Master and Slave Serial Peripheral Interface
  - Supports speeds up  $\frac{1}{4}$  of system clock
    - Mode fault error
    - Write collision error
  - Software selectable polarity and phase of serial clock SCK
  - System errors detection
  - Allows operation from a wide range of system clock frequencies (build-in 5-bit timer)
  - Interrupt generation
- I2C bus controller - Master
  - 7-bit and 10-bit addressing modes
  - NORMAL, FAST, HIGH speeds
  - Multi-master systems supported
  - Clock arbitration and synchronization
  - User defined timings on I2C lines
  - Wide range of system clock frequencies
- I2C bus controller - Slave
  - NORMAL, FAST and HIGH speed modes
  - Wide range of system clock frequencies
  - User defined data setup time on I2C lines

## LICENSING

Comprehensible and clearly defined licensing methods without royalty per chip fees make using of IP Core easy and simply.

Single Site license option is dedicated for small and middle sized companies making its business in one place.

Multi Sites license option is dedicated for corporate customers making its business in several places. Licensed product can be used in selected branches of corporate.

In all cases number of IP Core instantiations within a project, and number of manufactured chips are unlimited. The license is royalty per chip free. There is no time of use restrictions.

There are two formats of delivered IP Core

- VHDL, Verilog RTL synthesizable source code called HDL Source
- FPGA EDIF/NGO/NGD/QXP/VQM called Netlist

## DELIVERABLES

- ◆ Source code:
  - ◇ VHDL Source Code or/and
  - ◇ VERILOG Source Code or/and
  - ◇ Encrypted, or plain text EDIF netlist
- ◆ VHDL & VERILOG test bench environment
  - ◇ Active-HDL automatic simulation macros
  - ◇ ModelSim automatic simulation macros
  - ◇ Tests with reference responses
- ◆ Technical documentation
  - ◇ Installation notes
  - ◇ HDL core specification
  - ◇ Datasheet
- ◆ Synthesis scripts
- ◆ Example application
- ◆ Technical support
  - ◇ IP Core implementation support
  - ◇ 3 months maintenance
    - Delivery the IP Core updates, minor and major versions changes
    - Delivery the documentation updates
    - Phone & email support

## CONFIGURATION

The following parameters of the DRPIC166X core can be easy adjusted to requirements of dedicated application and technology. Configuration of the core can be prepared by effortless changing appropriate constants in package file. There is no need to change any parts of the code.

- Number of hardware stack levels - 1-16  
- default 8
- Memories type - synchronous  
- asynchronous
- RAM extension - 32 KB  
- 512 B - default
- SLEEP mode - used  
- unused
- WATCHDOG Timer - used / width  
- unused
- Timer 0, 1, 2 system - used  
- unused
- Compare Capture PWM - used  
- unused
- USART - used  
- unused
- PORTS A,B,C,D - used  
- unused
- DoCD™ Debug Unit - used  
- unused

## SYMBOL

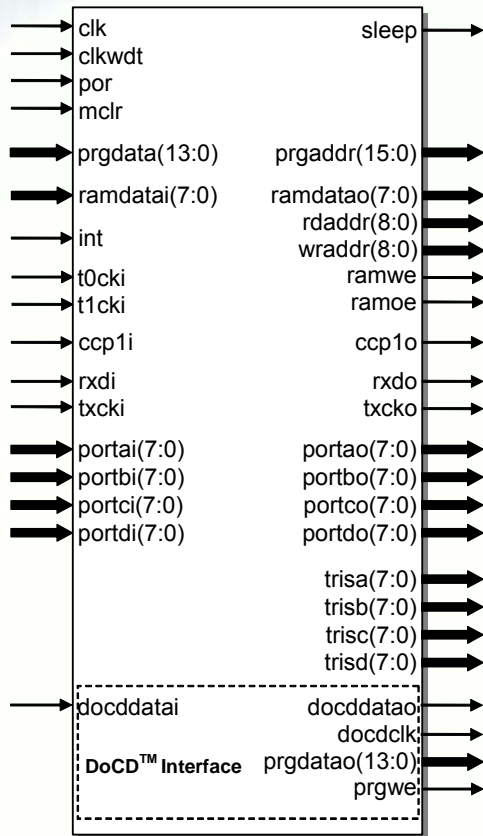

## PINS DESCRIPTION

PIN	TYPE	DESCRIPTION
clk	input	Global clock
clkwdt	input	Watchdog clock
por	input	Global reset Power On Reset
mclr	input	User reset
prgdata[13:0]	input	Data bus from program memory
ramdati[7:0]	input	Data bus from int. data memory
Int	input	External interrupt
t0cki	input	Timer 0 input
t1cki	input	Timer 1 input
ccp1i	input	Compare Capture channel input
rxd	input	USART serial data input
txck	input	USART serial clock input
portxi[7:0]	input	Port A, B, C, D input
docddatai	input	DoCD™ Debugger input
prgaddr[15:0]	output	Program memory address bus
ramdatao[7:0]	output	Data bus for internal data memory
rdaddr[8:0]	output	RAM read address bus
wraddr[8:0]	output	RAM write address bus

ramwe	output	Data memory write
ramoe	output	Data memory output enable
sleep	Output	Sleep signal
ccp1o	Output	Compare Capture channel output
txcko	Output	USART serial clock output
rxdto	Output	USART serial data output
portxo[7:0]	Output	Port A, B, C, D outputs
trisx[7:0]	Output	Ports A, B, C, D data direction pins
docddatao	Output	DoCD™ Debugger data output
docclk	Output	DoCD™ Clock line
prgdatao[13:0]	Output	Program Memory data output
prgwe	Output	Program Memory write enable

## BLOCK DIAGRAM

**ALU** – Arithmetic Logic Unit performs arithmetic and logic operations during execution of an instruction. This module contains work register (W) and Status register.

**Control Unit** – It performs the core synchronization and data flow control. This module manages execution of all instructions. Performs decode and control functions for all other blocks. It contains program counter (PC) and hardware stack.

**Hardware Stack** – it's a configurable hardware stack. The stack space is not a part of either program or data space and the stack pointer is not readable or writable. The PC is pushed onto the stack when CALL instruction is executed or an interrupt causes a branch. The stack is popped while RETURN, RETFIE and RETLW instruction execution. The stack operates as a circular buffer. This means that after the stack has been pushed eight times, the ninth push overwrites the value that was stored from the first push.

**RAM Controller** – It performs interface functions between Data memory and DRPIC166X internal logic. It assures correct Data Memory addressing and data transfers. The DRPIC166X supports two addressing modes: direct or indirect. In Direct Addressing the 9-bit direct address is computed from RP(1:0) bits (STATUS) and 7 least significant bits of instruction word.

Indirect addressing is possible by using the INDF register. Any instruction using INDF reg-

ister actually accesses data pointed to by the file select register FSR. Reading INDF register indirectly will produce 00h. Writing to the INDF register indirectly results in a no-operation. An effective 9-bit address is obtained by concatenating the IRP bit (STATUS) and the 8-bit FSR register.

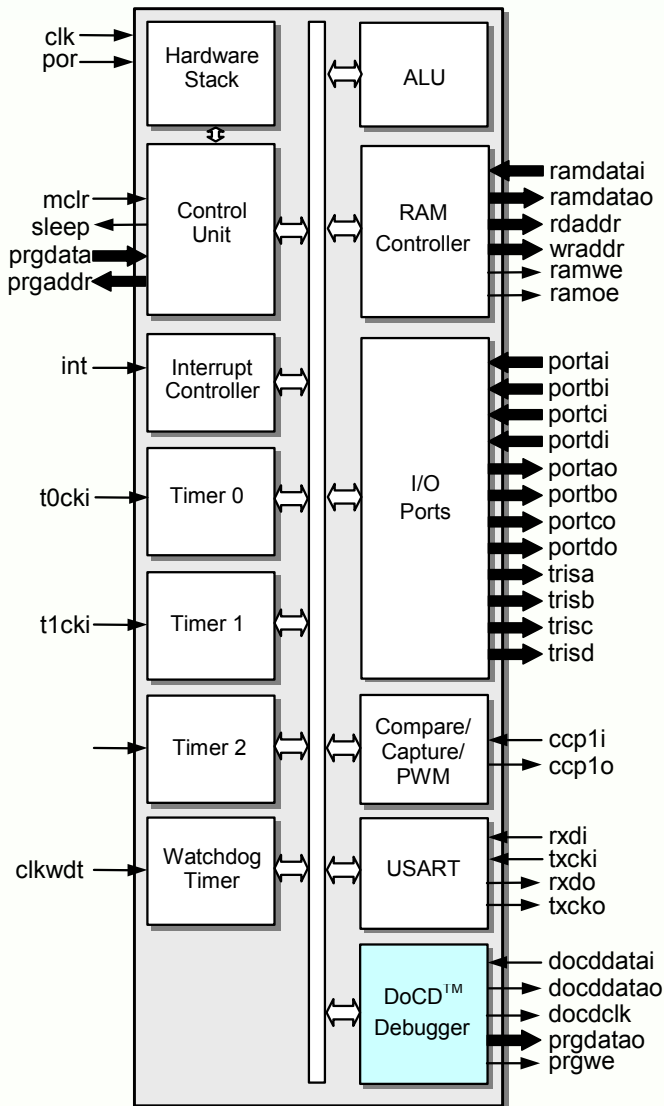

**Timer 0** – Main system's timer and prescaler. This timer operates in two modes: 8-bit timer or 8-bit counter. In the "timer mode", timer registers are incremented every 4 CLK periods. When the prescaler is assigned into the TIMER prescale ration can be divided by 2, 4 .. 256. In the "counter mode" the timer register is incremented every falling or rising edge of T0CKI pin, dependent on T0SE bit in OPTION register.

**Timer 1** – Timer 1 is a 16-bit timer consisted of two 8-bit registers (TMR1H and TMR1L). Timer 1 can operate either as a 16 bit timer incremented every CLK clock period or as a Counter incremented by rising edge on the T1CKI input pin. The Timer1 interrupt is generated by the timer overflow.

**Timer 2** – Is a 8-bit Timer with a prescaler and postscaler. Timer2 is suitable as PWM time-base. The Timer2 module has an 8-bit period register, PR2. Timer2 is incremented until it matches PR2 and then resets on the next increment cycle. The match output of the TMR2 register goes through a 4-bit postscaler to generate a TMR2 interrupt.

**Interrupt Controller** – Interrupt Controller module is responsible for interrupt manage system for the external and internal interrupt sources. It contains interrupt related registers called INTCON, PIE1, PIR1. There are seven individually maskable interrupt sources:

- ◆ Two external interrupts – INT pin, PORTB change (pins B7:B4)
- ◆ Five internal interrupts – Timers 0, 1, 2, USART, CCP1

The interrupt control register INTCON and PIR1 records individual interrupt requests in flag bits. A global interrupt enable bit, GIE and Peripheral interrupts enable bit, PIE enables all unmasked interrupts. Each interrupt source has an individual enable bit, which can enable or disable corresponding interrupt. When an interrupt is responded to, the GIE is cleared to disable any further interrupt, the return address is pushed into the stack and the PC is loaded with 0004h. The interrupt flag bits must be cleared in software before re-enabling interrupts.

**I/O Ports** – Block contains DRPIC166X's general purpose I/O ports and data direction registers (TRIS). The DRPIC166X has four 8-bit full bi-directional ports PORT A, PORT B, PORT C, PORT D. Each port's bit can be individually accessed by bit addressable instructions. Read and write accesses to the I/O port are performed via their corresponding SFR's PORTA, PORTB, PORTC, PORTD. The reading instruction always reads the status of Port pins. Writing instructions always write into the Port latches. Each port's pin has an corre-

sponding bit in TRISA, B, C and D registers. When the bit of TRIS register is set this means that the corresponding bit of port is configured as an input (output drivers are set into the High Impedance).

**CCP/PWM** – The CCP module contains a 16-bit register which can operate as a 16-bit capture register, 16-bit compare register, or as a PWM master/slave duty cycle register.

**Watchdog Timer**– it's a free running timer. WDT has own clock input separate from system clock. It means that the WDT will run even if the system clock is stopped by execution of SLEEP instruction. During normal operation, a WDT time-out generates a Watchdog reset. If the device is in SLEEP mode the WDT time-out causes the device to wake-up and continue with normal operation.

**USART** – The Universal Synchronous Asynchronous Receiver Transmitter module is also known as a Serial Communication Interface (SCI). The USART can be configured as a full duplex asynchronous system that can communicate with peripheral devices or it can be configured as a half duplex synchronous system (Master or Slave).

**DoCD™ Debug Unit** – it's a real-time hardware debugger provides debugging capability of a whole SoC system. In contrast to other on-chip debuggers DoCD™ provides non-intrusive debugging of running application. It can halt, run, step into or skip an instruction, read/write any contents of microcontroller including all registers, internal, external, program memories, all SFRs including user defined peripherals. Hardware breakpoints can be set and controlled on program memory, internal and external data memories, as well

as on SFRs. Hardware breakpoint is executed if any write/read occurred at particular address with certain data pattern or without pattern. The DoCD™ system includes three-wire interface and complete set of tools to communicate and work with core in real time debugging. It is built as scalable unit and some features can be turned off to save silicon and reduce power consumption. A special care on power consumption has been taken, and when debugger is not used it is automatically switched in power save mode. Finally whole debugger is turned off when debug option is no longer used.

## IMPROVEMENT

Most instruction of DRPIC166X is executed within 1 CLK period, except program branches that require 2 CLK periods. The table below shows sample instructions execution times:

Mnemonic operands	DRPIC166X (CLK cycles)	PIC16C6X (CLK cycles)	Impr.
ADDWF	1	4	4
ANDWF	1	4	4
RLF	1	4	4
BCF	1	4	4
DECFSZ	1(2) <sup>1</sup>	4(8) <sup>1</sup>	4
INCFSZ	1(2) <sup>1</sup>	4(8) <sup>1</sup>	4
BTFSC	1(2) <sup>1</sup>	4(8) <sup>1</sup>	4
BTFSS	1(2) <sup>1</sup>	4(8) <sup>1</sup>	4
CALL	2	8	4
GOTO	2	8	4
RETFIE	2	8	4
RETLW	2	8	4
RETURN	2	8	4

<sup>1</sup> - number of clock in case that result of operation is 0.

## DFPIC&DRPIC FAMILY OVERVIEW

The family of DCD DFPICXX & DRPICXX IP Cores combine a high-performance, low cost, and small compact size, offering the best price/performance ratio in the IP Market. The DCD's Cores are dedicated for use in cost-sensitive consumer products, computer peripherals, office automation, automotive control systems, security and telecommunication applications.

DCD's DFPICXX & DRPICXX IP Cores family contains four 8-bit microcontroller Cores to best meet your needs: DFPIC165X 12-bit program word, DFPIC1655X 14-bit program word, and DRPIC1655X and DRPIC166X single cycle microcontrollers with 14-bit program word. All three microcontroller cores are binary compatible with widely accepted PIC16C5X and PIC16CXXX. They employ a modified RISC architecture two or four times faster than the original ones.

The DFPICXXX & DRPICXX IP Cores are written in pure VHDL/VERILOG HDL languages which make them technologically independent. All of the DFPICXX & DRPICXX family members supports a power saving SLEEP mode and allows the user to configure the watchdog time-out period and a number of hardware stack levels. DFPICXX & DRPICXX can be fully customized according to customer needs.

Design	Program Memory space	Program word length	Data Memory space	Number of instructions	I/O Ports	Timer 0	Timer 1	Timer 2	Watchdog Timer	CCP1	USART	Sleep Mode	External interrupts	Internal Interrupts	Wake up on port pin change	Speed rate	DoCD™ Debugger	Size (gate)
DFPIC165X	2k	12	128	33	24	✓	-	-	✓	-	-	✓	-	-	-	2	-	2 700
DFPIC1655X	64k	14	32k	35	16	✓	-	-	✓	-	-	✓	5	1	✓	2	✓*	3 900
DFPIC166X	64k	14	32k	35	32	✓	✓	✓	✓	✓	✓	✓	5	5	✓	2	✓*	6 000
DRPIC1655X	64k	14	32k	35	32	✓	-	-	✓	-	-	✓	5	1	✓	4	✓*	4 800
DRPIC166X	64k	14	32k	35	32	✓	✓	✓	✓	✓	✓	✓	5	5	✓	4	✓*	6 700

\* Optional

*DFPIC & DRPIC family of High Performance Microcontroller Cores*

## CONTACT

For any modification or special request please contact to Digital Core Design or local distributors.

### Headquarters:

Wroclawska 94

41-902 Bytom, POLAND

e-mail: [info@dcd.pl](mailto:info@dcd.pl)

tel. : +48 32 282 82 66

fax : +48 32 282 74 37

### Distributors:

Please check <http://www.dcd.pl/apartn.php>