

# DFPMU-DP

## Floating Point Coprocessor

### Double Precision

v. 3.05

#### OVERVIEW

DFPMU-DP is a Floating Point Coprocessor, designed to assist CPU in performing the floating point mathematic computations. DFPMU-DP directly replaces C software functions, by equivalent, very fast hardware operations, which significantly accelerate system performance. It doesn't require any programming, so it also doesn't require any modifications to be made in the main software. Everything is done automatically, during software compilation by the DFPMU-DP C driver.

DFPMU-DP was designed to operate with DCD's DP8051, but can also work with any other 8-, 16- and 32-bit processor. Drivers for all popular 8051 C compilers, are delivered together with the DFPMU-DP package.

DFPMU-DP uses the specialized CORDIC and standard algorithms, to compute math functions. It supports **addition, subtraction, multiplication, division, square root**, comparison, and trigonometric functions: **sine, cosine, tangent and arctangent**. It has built-in conversion instructions from integer type to floating point type and vice versa. The input numbers format is compliant with IEEE-754 standard. DFPMU-DP supports double and single precision real numbers, 8-bit, 16-bit, 32-bit and 52-bit integers. **Each floating point function can be turned on/off** at configuration level, providing flexible scalability of DFPMU-DP module. It allows to save silicon space and provides exact configuration, required by certain applications.

DFPMU-DP is a technology independent design, that can be implemented in a variety of process technologies.

#### APPLICATIONS

- Math coprocessors
- DSP algorithms
- Embedded arithmetic coprocessor
- Fast data processing & control

#### KEY FEATURES

- **Direct replacement** for C double, float software functions, such as: +, -, \*, /, ==, !=, >=, <=, <, >
- Configurability of all available functions
- C interface supplied for all popular compilers: GNU C/C++, 8051 compilers
- No programming required
- IEEE-754 Double precision real format support – **double type**
- IEEE-754 Single precision real format support – **float type**
- 8-bit, 16-bit 32-bit and 52-bit integers format supported – **integer types**
- Flexible arguments and result registers location
- Performs the following functions:
  - *FADD, FSUB* – addition, subtraction
  - *FMUL, FDIV* – multiplication, division
  - *FSQRT* – square root
  - *FXAM* – examine input data
  - *FUCOM* – comparison
  - *FSIN, FCOS* – sine, cosine
  - *FTAN* – tangent
  - *FATAN* – arctangent
  - *FCLD, FILD* – 8-bit, 16-bit integer to double
  - *FLLD, FELD* – 32-bit, 52-bit integer to double
  - *FCST, FIST* – double to 8-bit, 16-bit integer
  - *FLST, FEST* – double to 32-bit, 52-bit integer
  - *FFLD* – float to double
  - *FFST* – double to float
- Exceptions built-in routines
- **Masks each exception indicator:**

- Precision lack PE
- Underflow result UE
- Overflow result OE
- Invalid operand IE
- Division by zero ZE
- Denormal operand DE
- Fully configurable
- Fully synthesizable, static synchronous design with no internal tri-states

## DELIVERABLES

- ◆ Source code:
  - VHDL Source Code or/and
  - VERILOG Source Code or/and
  - Encrypted Netlist or/and
  - plain text EDIF netlist
- ◆ VHDL & VERILOG test bench environment
  - Active-HDL automatic simulation macros
  - NCSim automatic simulation macros
  - ModelSim automatic simulation macros
  - Tests with reference responses
- ◆ Technical documentation
  - Installation notes
  - HDL core specification
  - Datasheet
- ◆ Synthesis scripts
- ◆ Example application
- ◆ Technical support
  - IP Core implementation support
  - 3 months maintenance
    - Delivery the IP Core updates, minor and major versions changes
    - Delivery the documentation updates
    - Phone & email support

## LICENSING

Comprehensible and clearly defined licensing methods, without royalty-per-chip fees, make using of IP Core easy and simple.

Single Site license option – it is dedicated for small and middle sized companies, running their business at one location.

Multi Sites license option – it is dedicated for corporate customers, running their business at several places. Licensed product can be used in selected company branches. In all cases, number of IP Core instantiation within a project and number of manufactured chips are unlimited.

The license is royalty-per-chip free. There is no restrictions regarding the time of use.

There are two formats of delivered IP Core

- VHDL, Verilog RTL synthesizable source code called HDL Source
- FPGA EDIF/NGO/NGD/QXP/VQM called Netlist

## SYMBOL

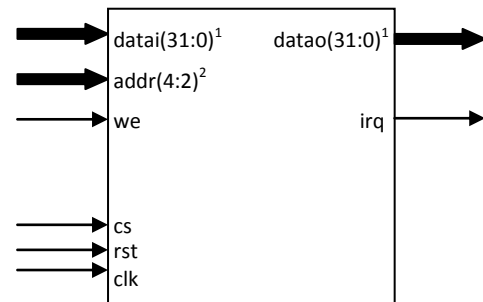

## PINS DESCRIPTION

PIN	TYPE	DESCRIPTION
clk	Input	Global system clock
rst	Input	Global system reset
cs	Input	Chip select for read/write
datai[31:0] <sup>1</sup>	Input	Data bus input
addr[4:2] <sup>2</sup>	Input	Register address to read/write
we	Input	Data write enable
datao[31:0] <sup>1</sup>	Output	Data bus output
irq	Output	Interrupt request indicator

1 – data bus can be configured as 8-, 16- or 32- bit depends on processor's bus size

2 – address bus is aligned to work with 8- (3:0), 16- (3:1) or 32- (4:2) bit processors

## BLOCK DIAGRAM

**Mantissa** – performs operations on mantissa part of number. The addition, subtraction, multiplication, division, square root, comparison and conversion operations are executed in this module. It contains mantissas and work registers.

**CORDIC** – performs trigonometric operations on input data. The sine, cosine, tangent and arctangent operations, are executed in this module. It contains three work registers.

**Exponent** – performs operations on exponent part of number. The addition, subtraction, shifting, comparison and conversion operations, are exe-

cuted in this module. It contains exponents and work registers.

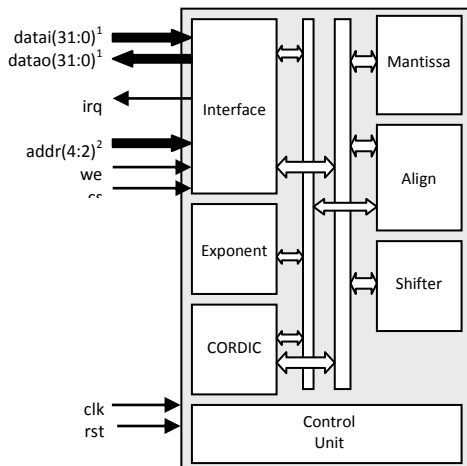

**Align** – performs the numbers analysis against IEEE-754 standard compliance. Information about the data classes are passed as result to appropriate internal module.

**Shifter** – performs mantissa shifting, during normalization and denormalization operations. Information about shifted-out bits are stored for rounding process.

**Control Unit** – manages execution of all instructions and internal operation, required to execute particular function.

**Interface** – makes interface between external device and DFPMU-DP internal 32-bit modules. It contains data, control and status registers. It can be configured to work with 8-, 16- and 32-bit processors.

## PERFORMANCE

The following table gives a survey about the Core area and performance in the XILINX® devices after Place & Route (all key features have been included):

Device	Speed grade	Slices	F <sub>max</sub>
VIRTEX-II	-6	3820	77 MHz
VIRTEX-IIP	-7	3810	99 MHz
VIRTEX-4	-11	3700	93 MHz
VIRTEX-5	-1	2150	121 MHz

Core performance in XILINX® devices

DFPMU-DP floating point instructions performance, has been compared to standard C library functions, delivered with every commercial C compiler. Each program was executed in the same system environments. Number of clock periods were measured between input data loading into work registers and output result storing after operation. The results are placed in the table below. Improvement has been computed as number of: (CPU CLK) divided by (CPU+DFPMU-DP CLK), required to execute particular instruction.

IEEE-754 FP Instruction	Improvement
Addition	12.0
Subtraction	11.7
Multiplication	10.6
Division	15.0
Square Root	21.5
Sine	52.0
Cosine	60.8
Tangent	97.9
Arcs Tangent	78.7
<b>Average speed improvement:</b>	<b>38.3</b>

More details are available in the core documentation.

The following table gives a survey about the 32-bit CPU+DFPMU-DP performance, compared to standard 32-bit RISC CPU.

Device	Improvement
32-bit RISC	1.0
32-bit RISC+DFPMU (arithmetic)	14.1
32-bit RISC+DFPMU (trigonometric)	72.4
<b>32-bit RISC+DFPMU (overall)</b>	<b>38.8</b>

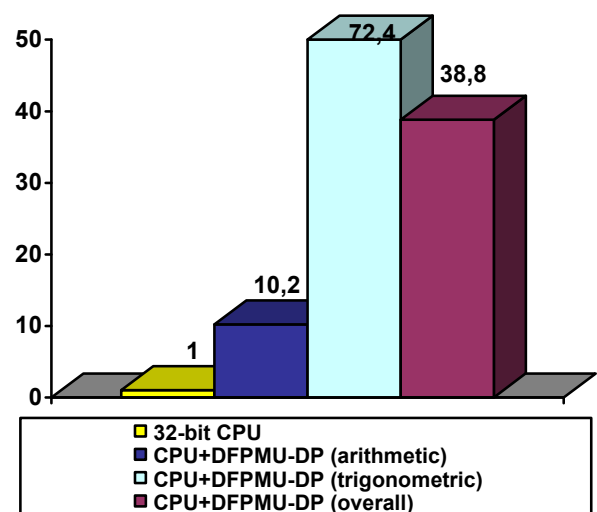



## CONTACT

For any modification or special request, please contact Digital Core Design or local distributors.

### Headquarters:

Wroclawska 94

41-902 Bytom, POLAND

*e-mail:* : [info@dcd.pl](mailto:info@dcd.pl)

*tel.* : +48 32 282 82 66

*fax* : +48 32 282 74 37

### Distributors:

Please check: <http://dcd.pl/sales/>